

II-VI INFRARED

www.iiviinfrared.com

CO₂ & FIBER LASER NOZZLES AND ACCESSORIES



CKY®



TOLL FREE 888.558.1504 (USA and Canada)
TEL. 724.352.1504 FAX. 724.352.4980

VOL. MA16



About II-VI INFRARED

In 1971, II-VI Incorporated began by exclusively producing the highest-quality cadmium telluride (CdTe) material available for manufacturing high-power industrial CO₂ laser optics. Today, we have diversified into producing zinc selenide (ZnSe) material, as well as into numerous business units including laser tools for materials processing (HIGHYAG); near-infrared optics, YAG components, and telecommunications components (VLOC); fiber optics, projection and display optics, DPSS laser, crystal materials, and other photonics products (Photop); defense and aerospace optics (Exotic Electro-Optics); tellurium and selenium products (PRM); thermoelectric cooling devices (Marlow Industries); silicon carbide (II-VI WBG); and advanced materials development (II-VI AMDC). Given this diversity of II-VI Incorporated's business units, we have thus christened our original IR materials and optics business unit II-VI Infrared.

As II-VI Incorporated continues to grow, II-VI Infrared focuses on the company's original, industry-leading products: infrared and CO₂ laser optics and materials. And thanks to decades of innovation in zinc selenide (ZnSe) and zinc sulfide (ZnS) materials processing, thin-film coating, precision diamond turning, and finished optics fabrication, II-VI Infrared is the world leader in CO₂ laser optics, delivering an unbeatable combination of innovation, quality, and expertise. II-VI Infrared also delivers the largest vertically integrated CO₂ laser optics manufacturing process -- from raw materials to finished coated products -- in the world.

An optics foundry to CO₂ laser original equipment manufacturers (OEMs) the world over, consistently building optics to spec with consistent performance and quality, II-VI Infrared's products range from replacement CO₂ laser optics and nozzles to lenses, partial reflectors, windows, beamsplitters, mirrors, beam expanders, reflective phase retarders, scanning-laser system optics, diamond-turned custom optics, IR optical materials (ZnSe, ZnS, CVD Diamond), and more. Our products and reputation make us the number-one supplier to OEMs of CO₂ laser systems worldwide, while our capabilities are without rival in the industry.

Our diamond-turning facility is among the largest and most advanced in the world, offering services such as flycutting and multiple-axis turning, as well as fast and slow tool servos for custom optics. Single-point diamond-turning is used in finishing transmissive optics and mirrors in a variety of metals and IR materials.

Major investments in computer design programs, thin film evaporation equipment, clean rooms, and QA testing facilities enable us to offer a broad range of IR thin-film coatings. II-VI Infrared is known for designing and producing consistently low-absorption coatings for high-power CO₂ laser optics. Additionally, our talented and experienced engineering team using optical design software and CAD systems, designs and builds standard and custom optics as well as specialized mounts, components, and electro-optic assemblies.

Our quality assurance program includes comprehensive testing, documentation, and statistical analysis to ensure that each optic and component performs to customer requirements.

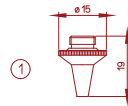

3-4



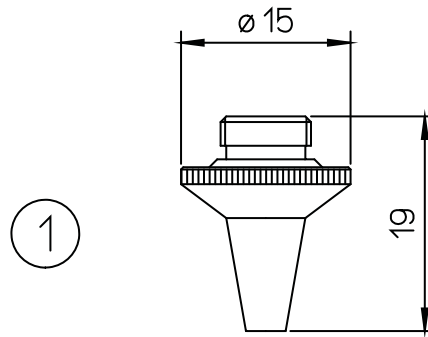



| POS | II-VI P/N | OEM P/N | DESCRIPTION |
|-----|-----------|---------|------------------|
| 1 | L1641 | 0 | CKY NOZZLE Ø 0.8 |
| | L1643 | 0 | CKY NOZZLE Ø 1.2 |



FOR ALL OF YOUR REPLACEMENT OPTIC NEEDS

CO₂ LASER OPTICS/CONSUMABLE PRODUCTS
 CO₂ LASER CONSUMABLES
 NOZZLES & ACCESSORIES
 TRUMPF CUT LENSES
 MP-5 ULTRA-LOW ABSORPTION LENSES
 ASPHERIC LENSES
 MENISCUS LENSES
 PLANO-CONVEX LENSES
 CYLINDER LENSES
 MIRRORS
 SCANNING LASER SYSTEM OPTICS
 BEAM COMBINERS
 BEAM EXPANDERS
 BEAMSPLITTERS
 COLLIMATING OPTICS
 DIAMOND-TURNED SPECIALTY OPTICS
 REFLECTIVE PHASE RETARDERS
 PRISMS & RHOMBS
 MODULATORS
 WAVEPLATES
 THIN-FILM POLARIZERS
 POLARIZER-ANALYZER-ATTENUATOR

RESONATOR OPTICS
 OUTPUT COUPLERS
 REAR MIRRORS
 BAND-SELECTIVE OPTICS
 AR-COATED WINDOWS
 BREWSTER WINDOWS
 PROTECTIVE WINDOWS
 LENS STRESS ANALYZER(LSA)
 1 MICRON OPTICS
 1 MICRON OPTICAL COMPONENTS
 1 MICRON DEBRIS SHIELDS
 1 MICRON HPDDL BEAM INTEGRATORS
 1 MICRON OPTICAL COATINGS
 1 MICRON MATERIALS
 OPTICAL MATERIALS
 ZINC SELENIDE (ZNSE)
 ZINC SULFIDE (ZNS)
 ZINC SULFIDE MULTISPECTRAL (ZNS MS)
 GERMANIUM (GE)
 GALLIUM ARSENIDE (GAAS)
 MATERIAL BLANKS
 CVD DIAMOND SUBSTRATES
 IR THERMAL IMAGING OPTICS



TOLL FREE 888.558.1504 (USA and Canada) T. 724.352.1504 F. 724.352.4980 WWW.II-VIINFRARED.COM

All original equipment manufacturer's names, drawings, colors, trademarks and part numbers are used for identification purposes only and we are in no way implying that any of our products are original equipment parts. All parts advertised for sale in this catalog are made for and/or by II-VI Incorporated.



WORLDWIDE SALES OFFICES

To place an order, contact a II-VI sales representative at any of the following locations, or visit www.iiviiinfrared.com/contact for our most complete and up-to-date contact information.

**II-VI INFRARED**

375 SAXONBURG BLVD
SAXONBURG, PA 16056
UNITED STATES
888-558-1504 (Toll free in USA)
T. 724-352-1504
F. 724-352-4980
info@iiviiinfrared.com

II-VI WEST

36570 BRIGGS ROAD
MURRIETA, CA 92563
USA
800.262.5273 (Toll free in USA)
T. 951.926.7640
F. 951.926.8218
info@iiviiinfrared.com

II-VI BENELUX N.V.

BAAIKENSSTRAAT 21/2
B-9240 ZELE
BELGIUM
T. 32 (0) 52 45 86 10
F. 32 (0) 52 45 86 11
sales@ii-vi.be

II-VI DEUTSCHLAND GmbH

BRUNNENWEG 19-21
D-64331 WEITERSTADT
GERMANY
T. 49 6150 54 39-226
F. 49 6150 54 39-200
ir.Info.de@ii-vi.com

II-VI ITALIA S.r.l.

VIA ANDREA COSTA
31-20131 MILANO
ITALY
T. 39 02 2828740
F. 39 02 26149131
ir.info.it@ii-vi.com

II-VI SUISSE S.a.r.l.

MOULIN-DU-CHOC
1122 ROMANEL-SUR-MORGES
SWITZERLAND
T. 41 2186 902 52
F. 41 2186 993 08
info@ii-vi.ch

II-VI UK LTD.

UNIT 20B, OAKHAM ENTERPRISE
PARK, ASHWELL ROAD, OAKHAM,
RUTLAND, LE15 7TU
UNITED KINGDOM
T. 44 1572 771 778
F. 44 1572 771 779
sales@ii-vi.co.uk

II-VI JAPAN

WBG MARIVE EAST 26F
NAKASE 2-6-1
MIHAMA-KU, CHIBA-SHI
CHIBA 261-7126
JAPAN
T. 81 43297 2693
F. 81 43297 3003
center@ii-vi.co.jp

II-VI SINGAPORE PTE. LTD.

BLK. 5012, TECHPLACE II
#04-07 & 05-07/12,
ANG MO KIO AVE. 5
SINGAPORE 569876
T. 65 6481 8215
F. 65 6481 8702
ir.sales.sg@ii-vi.com

II-VI INFRARED LASER(SUZHOU)

BLOCK D#01-01/02
NO. 5 XING HAN STREET
SUZHOU INDUSTRIAL PARK
SUZHOU, CHINA 215101
T. 86 512 6761 9295
F. 86 512 6767 1207
infosz@ii-vi.com.cn

II-VI KOREA

WEST 1502 HANSHIN INTERVALLEY
322 TEHERAN-RO
SEOUL, KOREA 06211
T. 82 2 6242 2626
F. 82 2 6242 2627
jchoi@ii-vi.com

II-VI TAIWAN

8FL, 285 SEC 2 TIDING BLVD.
TAIPEI 114, TAIWAN
REPUBLIC OF CHINA
T. 886 2 87512155
F. 886 2 26582276
ir.sales.tw@ii-vi.com